

# APECS® / BL 16 BICYCLE LOCK

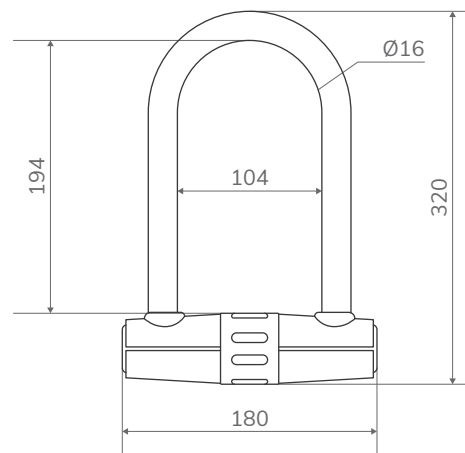

## A HIGH SECURITY OPTION FOR PROTECTING A BICYCLE

APECS BL 16 provides a high security option for protecting a bicycle, with a hardened steel 16mm shackle. The lock has been tested to Art 4051 4\*. A rubber protective coating keeps your frame paintwork scratch free. A double bolt locking mechanism gives the lock an extensive holding power and a high security disc style cylinder to withstand picking.



- ART 4051 certificate 4\*
- Hardened Steel shackle — 16mm
- Weatherproof
- Frost-resistant
- High-security locking mechanism

Material	Steel
Locking Mechanism	Disc tumbler
Height	320mm
Width	180mm
Shackle	Hardened Steel
Shackle height spacing	194mm
Shackle width spacing	104mm
Number of keys	2
Finish	Black & Grey

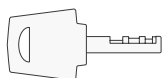

DISC TUMBLER KEY



ANTI-PICK



ANTI-SAW



WEATHERPROOF



ART



LAB TESTED