

PROTECTING THE HOME, THE WORKPLACE
AND SPACES BETWEEN

APECS[®]

DOOR MANUFACTURERS PRODUCT CATALOGUE

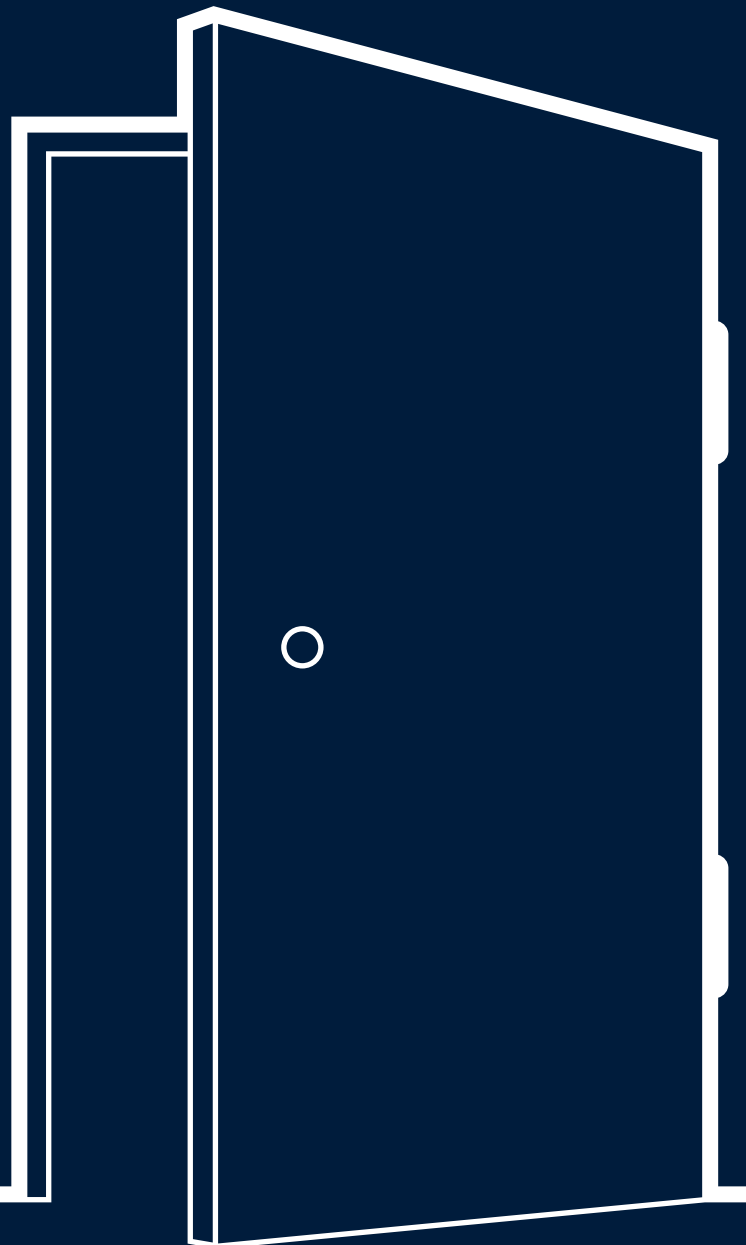

WE ARE DELIGHTED TO WELCOME YOU TO THE APECS UK PRODUCT COLLECTION FOR DOOR MANUFACTURERS.

THIS CATALOGUE WILL PROVIDE YOU WITH INITIAL INFORMATION ABOUT OUR PRODUCTS.

APECS RANGE OF PRODUCTS COVERS OVER 4000 ITEMS WORLDWIDE. IF YOU DIDN'T FIND WHAT YOU WERE LOOKING FOR IN THIS CATALOGUE, PLEASE LET US KNOW AND WE WILL DO OUR BEST TO SOURCE THE ITEM FOR YOU.

APECS ETHOS

WE ARE DEVOTED TO PERFORMANCE AND CUSTOMER SATISFACTION!

APECS has been a reliable partner to the international door manufacturing industry for over 25 years.

As a developer, manufacturer and direct distributor of locks, fittings, components and accessories, APECS offers a one-stop solution: from concept to research, development and manufacturing.

We work with our door manufacturing partners to ensure that they get the most cost-efficient quality locks and ironmongery that would suit their business and match the aesthetic needs of their products. From a technical perspective, we strive to make sure that each customer gets the correct specification for performance. Additionally, having our own factory ensures control throughout the supply chain to help us deliver every order on time.

From the moment an order comes through to the day our products are installed, each and every customer, no matter the size of the order, receives our best care. We aim to establish long-term relationships and support the growth of our customers year after year.



APECS HISTORY

APECS COMES FROM THE LATIN WORD “APEX”, WHICH MEANS “SUMMIT, PEAK, TOP”.

APECS is a leading manufacturer of door hardware and locking solutions. Established in 1992, we are a family run business. We value close-knit relations with associates and customers all over the world, while operating from five sites in London, Beijing, Ljubljana, Kharkiv, and Moscow. We employ over 600 staff across three continents and we are thrilled to continue expanding. Over the last 25 years APECS has established itself as a producer of high quality security products and a trustworthy partner in the lock industry.

APECS comes from the Latin word “apex”, which means “summit, peak, top”. Striving to be the best is embedded in our name and vision. To us, this means creating products that benefit our customers’ personal and professional space. We have succeeded by staying true to our priorities – to adhere to the customer's desires and needs. We learn and grow every day and aim to make people’s lives safer. Our factory, testing laboratories and innovation centres guarantee high quality standards and secure protection for customers worldwide.

Despite entering the UK market only a few years ago, we have firmly established our supply chain and sales support in the union. We operate from our main office in London’s Chelsea Harbour and have a dedicated team dealing with operations, manufacturing, customer service and marketing. Our main aim is to ensure that every APECS customer receives bespoke treatment, regardless of the size of the order.

1992 APECS LAUNCHES IN RUSSIA	1995 MANUFACTURING EXPANDS TO CHINA
2005 NEW WAREHOUSE AND HQ IN MOSCOW	2000 FIRST BEIJING OFFICE OPENS
2007 APECS EXPANDS TO CIS & WESTERN EUROPE	2009 APECS VENTURES INTO RETAIL (B&Q, LEROY MERLIN AND OBI)
2017 APECS CELEBRATES 25TH ANNIVERSARY	2014 LONDON OFFICE LAUNCHES A UK SPECIFIC PRODUCT RANGE



OUR PRODUCTS

APECS delivers an extensive range of products including cylinders, locks, door closers, latches, handles, padlocks, hinges and door accessories such as door viewers, escutcheons, turn and release and door stops. Each range consists of various products with different levels of security. We provide a comprehensive range of Euro Profile cylinders and locks suitable for all types of doors and security needs. These then meet the functional and aesthetic requirements of residential and commercial applications.



OUR FACTORY

Our factory in China has operated for more than 14 years. We ensure top-quality output and that production standards are complied with for our own range of APECS-branded products, as well as the variety of solutions for the OEM market. There are more than 140 staff members in the factory, who are involved in all stages of lock development and manufacturing.



OUR LABORATORIES

Our own laboratories are equipped with state-of-the-art technologies to ensure that all products are manufactured in compliance with the highest standards set by European, Russian and US testing authorities. Among others, we conduct human intervention tests, machine cylinder snapping, corrosion and durability tests. Our experienced R&D team thoroughly monitors all stages of the development process and subjects all products to rigorous testing.



OUR TEAM

Our employees are the main reason we are able to deliver great products, services and experiences to our customers around the world every day. We employ over 600 staff and believe in rewarding them for their efforts. We are very proud that many of our employees have been with APECS since the beginning.

OUR MISSION



OUR VISION

We strive to make people feel safe and protected. We mobilise our expertise, innovations and global partnerships to manufacture solutions that guarantee protection and security for people worldwide.



OUR MISSION

We invest our experience to consistently provide our customers with superior quality hardware products that satisfy their needs and exceed expectations. We work to create solutions that are timely and affordable to all.



OUR VALUES

Our purpose is to guarantee security and we are devoted to performance and customer satisfaction. We strive to be trusted, respected and valued by our partners and customers.

GUARANTEE SECURITY

We know our customers want to feel and be safe. We aim to provide excellence, value and innovative products to ensure safety throughout.

WORK AS A TEAM

We work as a tight-knit team. We are purpose-driven, diverse and share a passion for creating and achieving mutual goals.

THINK LONG TERM

We know we succeed only when our customers and partners succeed. We do business in an open, direct and sustainable way.

APECS LOCATIONS

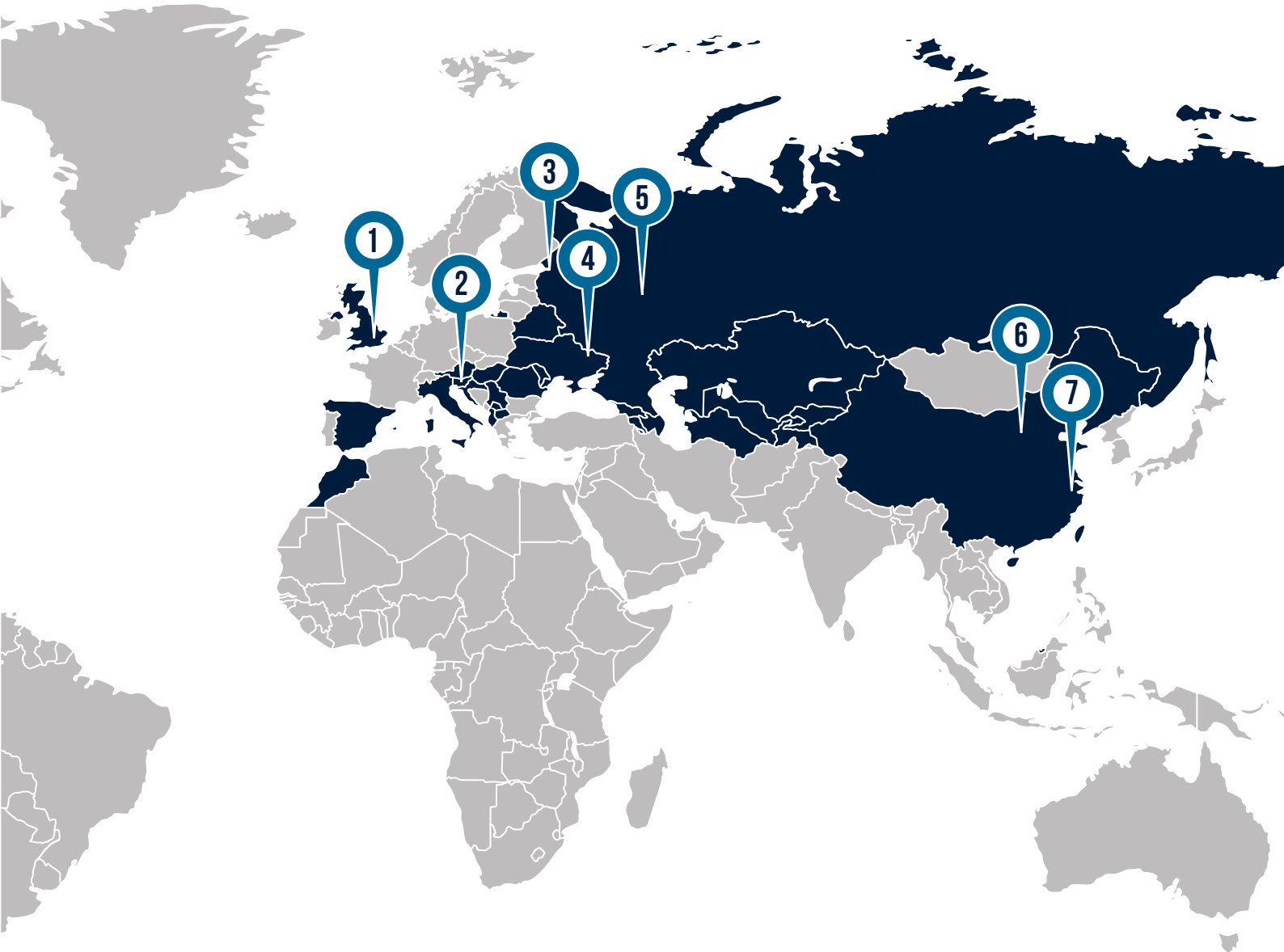

APECS OFFICES:

1. London
2. Ljubljana
3. St. Petersburg
4. Kharkiv
5. Moscow
6. Beijing
7. Shanghai

APECS PRESENCE:

Albania, Armenia, Austria, Azerbaijan, Belarus, China, Croatia, Georgia, Hungary, Italy, Kazakhstan, Kosovo, Kyrgyzstan, Macedonia, Moldova, Morocco, Poland, Romania, Russia, Serbia, Slovenia, Spain, Tajikistan, Turkmenistan, Ukraine, United Kingdom, Uzbekistan

APECS CYLINDERS

	AP	N6
		
		
TS 007 Rating	3 Star	1 Star
Key type	Restricted Dimple Key	Dimple key
Key way	Horizontal	Horizontal
Number of pins	9	5 or 6
Number of Differs	In excess 180,000	In excess of 117,000
Sizes	70-110mm and offsets	62-110mm and offsets
Variations	Key-Key & Thumbturn	Key-Key, Thumbturn and Single
Number of keys	3	3
Finish	Brushed Brass or Brushed Satin Nickel	Brushed Brass or Satin Nickel

	XS	BC
		
		
TS 007 Rating	1 Star	N/A
Key type	Standard key	Standard Key
Key way	Vertical	Vertical
Number of pins	6	6
Number of Differs	In excess 117,000	In excess 15000
Sizes	60-110mm and offsets	60-110mm and offsets
Variations	Key-Key, Thumbturn and Single	Key-Key, Thumbturn and Single
Number of keys	3	3
Finish	Brass or Satin Nickel	Brass or Nickel

AP CYLINDER

APECS AP — MAXIMUM LEVEL OF SECURITY AGAINST FORCED ENTRY METHODS OF ATTACK



THE APECS AP CYLINDER OFFERS MAXIMUM PROTECTION. IT SAFEGUARDS FROM ALL FORCED METHODS OF ATTACK, RANGING FROM SNAPPING, DRILLING, PLUG-EXTRACTION, PICKING AND BUMPING.

IT ALSO FEATURES AN INTERLOCKING MECHANISM WITH A UNIQUE CAM PROTECTION BLOCK AND IS OPERABLE FROM INSIDE WHEN THE LOCK IS TAMPERED WITH EXTERNALLY.

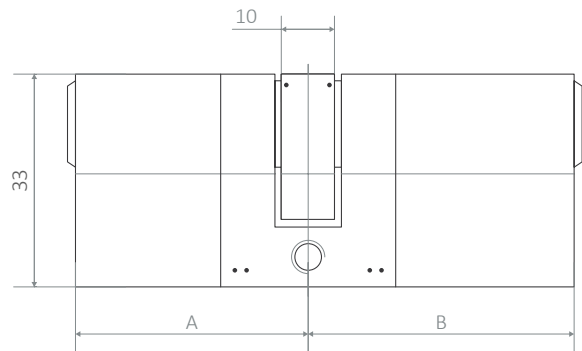

CERTIFICATES

- BSI 3 Star Kitemark – KM621947
- Sold Secure Diamond Standard – CLME08161454
- Tested to TS007:2014 A1:2015
- Tested to EN1303:2015 — 16000C6D

SECURITY INFORMATION

- Anti-pick: 4 anti-pick pins on each side
- Anti-bump: double locking mechanism with track rail pins in combination with a unique shallow chamber
- Anti-drill: 1 anti-drill pin on each side
- Snap-secure sacrificial point
- Restricted key profile
- 5-year guarantee

UNIQUE FEATURES:

- Double locking mechanism with additional track rail pins
- Patent pending interlocking mechanism and hardened cam protection block prevents from snapping and plug extraction
- Patent pending ball-bearing connection ensures additional operation smoothness and strong fixing between the cylinder core and the cam
- Operable from inside when lock is tampered with externally



N6 CYLINDER

APECS N6 CYLINDER SAFEGUARDS AGAINST COMMON METHODS OF ATTACK

DIMPLE KEY



APECS N6 IS A RESTRICTED PROFILE CYLINDER THAT OFFERS HIGH SECURITY SOLUTIONS AGAINST COMMON ATTACK METHODS.

N6 OFFERS PROTECTION AGAINST SNAPPING, PICKING, BUMPING, DRILLING AND PLUG EXTRACTION.

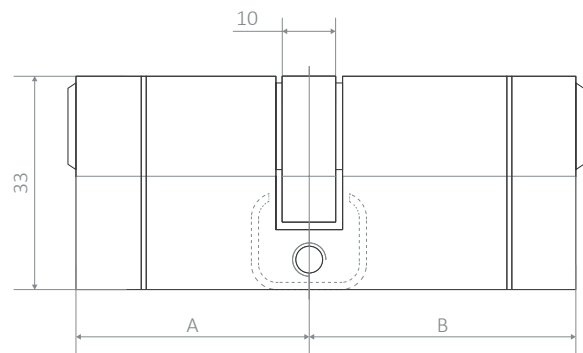

CERTIFICATES

- BSI 1 Star Kitemark – KM621947
- Tested to TS007:2014 A1:2015
- Tested to EN1303:2005 – 16000C62*

SECURITY INFORMATION

- 62mm has 5 pins, 62mm has 5 pins
- Anti-pick: 3 or 4 anti-pick pins on each side depending on size
- Anti-bump: shallow chamber
- Anti-drill: 3 anti-drill pins on each side with an additional anti-drill ball bearing
- Anti-plug extraction
- Sacrificial cut
- Brass differ and driver pins
- Stainless steel springs

UNIQUE FEATURES:

- U-shaped Stainless Steel protection pin and sacrificial cut
- Grub screws for easy repinning



XS CYLINDER

APECS XS CYLINDER PROVIDES RESISTANCE AGAINST COMMON METHODS OF ATTACK

STANDARD KEY



APECS XS OPEN PROFILE CYLINDER OFFERS A HIGH-SECURITY LOCKING SOLUTION AT AN AFFORDABLE PRICE.

THE CYLINDER OFFERS PROTECTION FROM MAIN FORCED ENTRY METHODS OF ATTACK: DRILLING, PICKING, BUMPING AND PLUG EXTRACTION.

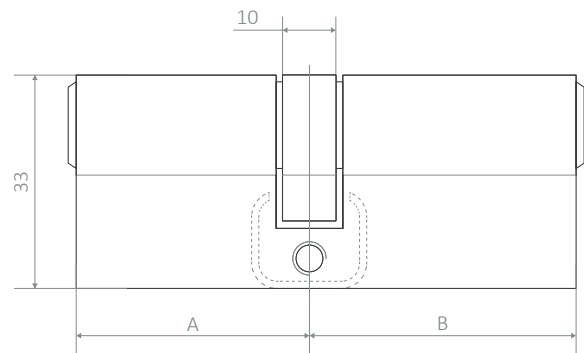

CERTIFICATES

- BSI 1 Star Kitemark – KM621947
- Tested to TS007:2014 A1:2015
- Tested to EN1303:2005 — 16000C62*

SECURITY INFORMATION

- Anti-pick: 4 anti-pick pins on each side
- Anti-bump: shallow chamber
- Anti-drill: 4 anti-drill pins on each side
- Anti-plug extraction
- Brass differ and driver pins
- Stainless Steel springs

UNIQUE FEATURES

- U-shaped Stainless Steel protection pin that prevents from plug extraction



Anti-pick



Anti-bump



Anti-drill



Plug extraction protection



BC CYLINDER

APECS BC STANDARD CYLINDER OFFERS A MODERATE LEVEL OF SECURITY AT A HIGHLY COMPETITIVE PRICE



APECS BC OPEN PROFILE CYLINDER IS SUITABLE FOR ANY EURO PROFILE LOCK AND WILL FIT UPVC, TIMBER AND ANY OTHER ENTRANCE DOORS WHEN SECURITY IS REQUIRED WITH A MODERATE LEVEL OF PROTECTION.

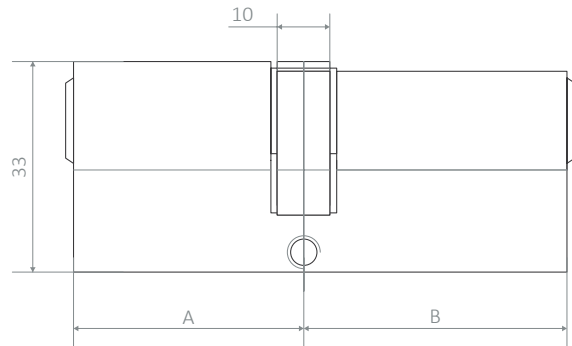

CERTIFICATES

- Tested to EN1303:2015 — 16000C30

SECURITY INFORMATION

- Brass driver and differ pins
- Single row — 6 pins





APECS

APECS FACTORY IN SHANGHAI:

- 140 EXPERIENCED STAFF MEMBERS
- IN-HOUSE RESEARCH AND DEVELOPMENT DEPARTMENT
- SUPPORTS SEVERAL LEADING BRANDS IN THE LOCK INDUSTRY WITH ITS EXPERTISE

APECS[®]

APECS CONSULT LTD

302-303 Harbour Yard, Chelsea Harbour,
London, SW10 0XD

Tel: +44 (0) 207 349 9888

WhatsApp: +44 (0) 792 883 2801

Web: www.apecs.co.uk